

# AEGIS™ -PHX Conventional Fire Alarm Suppression Control Unit

## FEATURES

- **Control for the following Kidde Fire Systems suppression systems:**
  - ECS™ -500 Clean Agent
  - ADS™ Clean Agent
  - Natura™ Inert Gases
  - HP CO2
  - LP CO2
  - WHDR™ Wet Chemical
  - IND™ Dry Chemical
- **Suppression systems by others:**
  - Sprinkler Supervisory
  - Deluge/Pre-action
  - Foam and Foam/Water
  - Water Mist
- **Input-Output Circuits Available:**
  - Seven (7) Class A or Class B Initiating Device Circuits
  - Five (5) Class A or Class B Releasing-Notification Appliance Circuits
  - Three (3) Programmable and 1 Trouble Form-C Relays
  - Two (2) Open Collector Programmable Outputs for external relay
  - Two (2) 24 VDC Regulated Auxiliary Power Outputs (interrupted or continuous power upon panel reset)
- **Enclosure:**
  - Meets NEMA 1 requirements when door is closed
  - Semi flush enclosure mounting option
  - Enclosure available with door-mounted Suppression Maintenance Disconnect Switch, Abort and Manual Release Switches
  - Door key lock
  - Earth Grounding studs provided
- **Power Supply:**
  - 120/240V, 50/60 Hz AC input, selected by switch on unit and on PCB
  - 5.4 A Power Supply Unit, filtered and regulated power
  - Battery charging capacity of 70-AH
  - Space provided at bottom of enclosure for two 12-AH sealed, lead-acid 12V batteries
  - Optional Large Capacity Battery Enclosure available
- **User Interface & Configuration:**
  - 4 Line, 40 character LCD Display
  - Status LEDs and Control Buttons on keypad
  - Flexible programming; Event-Output-Control (EOC) code available for tailoring to specific application
  - Configuration Utility provided for remote use
  - 15 Pre-Defined Configurations selectable at control unit and within remote configuration utility
  - Audible Buzzer produces 70 dBA at 3 feet away
- **Service & Configuration Aids:**
  - Easy to service, advanced diagnostics and event log
  - Ethernet connection for remote computer use
  - Optional IntelliSite™ IoT platform available
- **Backwards compatible with installed investment:**
  - Suitable for retrofitting existing installations without replacing back box (fits easily in AEGIS™, AEGIS™ 2.0, AEGIS™-XLT enclosure; requires PCB and door replacement only)
  - Legacy Fenwal Protection Systems and Chemetron Fire Systems Control Heads & Actuators supported
  - Legacy Fenwal Protection Systems Initiators supported
  - Majority of legacy detectors supported
- **Key Functionality:**
  - "Triple R" safeguards substantially reduce the risk of inadvertent release circuit activation caused by microprocessor failure or external electrical events
  - Spurt functionality
  - 5 Abort Types available, including New York City Abort sequence
  - Ground Fault Detection Circuit and Indicator
  - Real Time Clock
- **Approvals & Listings:**
  - Factory Mutual (FM) Approved
  - UL Listed, Meets Standard 864 for Control Units and Accessories for Fire Alarm Systems, 10th edition
  - California State Fire Marshal
  - City of New York Fire Department
  - Malaysian Fire and Rescue Department (BOMBA)
  - United Arab Emirates (UAE) RoHS and Civil Defense Certificate of Compliance
  - HFKD (Hong Kong)
  - Taiwan Fire Service



---

## **OVERVIEW**

The Kidde Fire Systems AEGIS™-PHX is a conventional suppression-focused fire alarm control unit which provides advanced configuration flexibility for single-zone and multi hazard fire suppression applications in commercial and industrial environments. With built-in safeguards to prevent inadvertent releases due to spurious signals, high degree of programming flexibility and a full complement of input and output circuits, the AEGIS-PHX is ideally suited for a wide range of special hazard extinguishing systems. While its 160-character backlit LCD provides easy access to system status, the event log and configuration menus, its enclosure and approved devices enables backwards compatibility with the installed base of ANSI/UL 864, 9th and 10th edition conventional control units sold under the Kidde Fire Systems and legacy Fenwal Protection Systems and Chemetron Fire Systems brands.

## **INITIATING DEVICE CIRCUITS (IDCs)**

The AEGIS-PHX has seven (7) programmable IDCs each of which can be configured for either conventional smoke detection, contact input from manual operators such as manual releases and abort stations or supervisory inputs such as flow switches, pressure switches and the like.

## **BACKWARDS COMPATIBLE WITH INSTALLED INVESTMENT**

The AEGIS-PHX is backwards compatible with legacy Kidde, Fenwal and Chemetron agent release devices (including control heads, initiators and actuators), notification appliances, detectors and fire extinguishing systems. The AEGIS-PHX can retrofit existing AEGIS, AEGIS 2.0 and AEGIS-XLT installations without the need to replace the enclosure back box (only PCB and door are substituted and easily fit in place of removed parts).

## **ENCLOSURE**

The AEGIS-PHX NEMA 1-rated enclosure is large enough to house the circuit board, the power supply unit and two 12 VDC, 12-AH batteries. It provides up to 2 inches (51 mm) of wiring and finger space between the circuit board and the cabinet wall.

## **BATTERIES**

Sealed, lead-acid 12V batteries up to 70-AH can be charged by the AEGIS-PHX control unit. For larger size batteries (greater than 12-AH), an optional wall-mounted battery enclosure is available, P/N 76-100010-001.

## **AUXILIARY POWER**

Two 24VDC auxiliary power outputs are provided and can be configured to interrupt power (if “resettable”) or keep power continuous (if “non-resettable”) when the AEGIS-PHX System Reset control key is pressed. Power will be interrupted for a period of 5 seconds after reset, if outputs are configured to be resettable.

## **R-NAC COMBO CIRCUITS (NAC or RELEASE)**

The AEGIS-PHX has five combination Release-Notification Appliance Circuits which can be configured as a NAC or as an Agent Release Circuit.

## **NOTIFICATION APPLIANCE CIRCUITS (NACs)**

When an R-NAC circuit is configured as a NAC, each circuit can provide up to 1.5 Amps @ 24 VDC for horns, strobes, bells, or other notification appliances. Power for notification appliances is fully filtered and regulated. Each NAC is programmable, and supports continuous and master-coded outputs for audible devices. NACs are supervised, power limited, and can be used with any 24 VDC regulated UL Approved appliances (suitable for synchronized and non-synchronized notification appliances such as Eaton/Wheelock).

## **RELEASE CIRCUITS**

When an R-NAC circuit is configured for releasing, it can be set up to actuate releasing devices in the following ways:

- One control head or solenoid valve
- One Kidde Fire Systems actuator
- Fenwal Protection Systems initiators

These releasing circuits can be used to actuate various Kidde control heads for clean agents, inert gas, low and/or high pressure carbon dioxide, watermist or sprinkler control that are FM Release Panel Group 3, rated 22W and below.

## **TRIPLE-R SAFEGUARD SYSTEM**

The releasing circuits are protected against inadvertent activation via the main microprocessor by a “Triple-R” (Triple Redundancy) safeguard system. The Triple-R system requires that the main microprocessor issue two release commands, of opposite polarity and via separate signaling channels and that these commands be combined with a signal from the control unit’s watchdog timer confirming proper microprocessor operation, in order to activate a release circuit. This triple-redundant release-command requirement ensures that an electrical transient or disturbance that temporarily interferes with the operation of the main microprocessor will not inadvertently activate an extinguishing system.

## **ON-BOARD RELAYS**

The AEGIS-PHX also includes four Form-C relays. Three of the four relays are user-programmable for any system condition and the fourth relay is dedicated to trouble conditions. Each relay is rated for 1 Amp @ 30 VDC.

## **EXTERNAL RELAYS**

The AEGIS-PHX control unit includes two individually-programmable relay output driver circuits (open collectors) to activate the coil on a customer-supplied relay.

## PROGRAMMING

The AEGIS-PHX Configuration Utility allows the control unit to be programmed for each individual, site-specific sequence of operation. All circuits and global parameters can be configured while away from the control unit. When completed, an Ethernet port directly connects from the computer to the control unit for easy and quick configuration file upload.

## PRE-PROGRAMMED CONFIGURATIONS

To make programming easier, 15 predefined sequence-of-operation/configuration files are available for selection within the Configuration Utility and at the control unit itself. These include:

- 1) AEGIS 2.0 Control Unit Default Configuration
- 2) All Inputs and Outputs Disabled
- 3) Cross Zone Activation
- 4) Cross Zone Activation of 1 ARC with Fire Alarm Only
- 5) Cross Zone Activation with NYC Abort
- 6) Cross Zone Activation with NYC Abort and Fire Alarm
- 7) Cross Zone Activation with Sprinkler Release
- 8) Single Zone Activation for HP-CO2 Release
- 9) Single Zone Activation for with Cycling LP-CO2 Release
- 10) Cross Zone Activation of Fire Alarm Only
- 11) Cross Zone Activation with Onboard Maintenance Bypass Switch
- 12) Cross Zone Activation of 1 ARC with Fire Alarm Only with Onboard Maintenance Bypass Switch
- 13) Cross Zone Activation with NYC Abort with Onboard Maintenance Bypass Switch
- 14) Cross Zone Activation with NYC Abort and Fire Alarm with Onboard Maintenance Bypass Switch
- 15) Cross Zone Activation with Sprinkler Release with Onboard Maintenance Bypass Switch

## DIMENSIONS

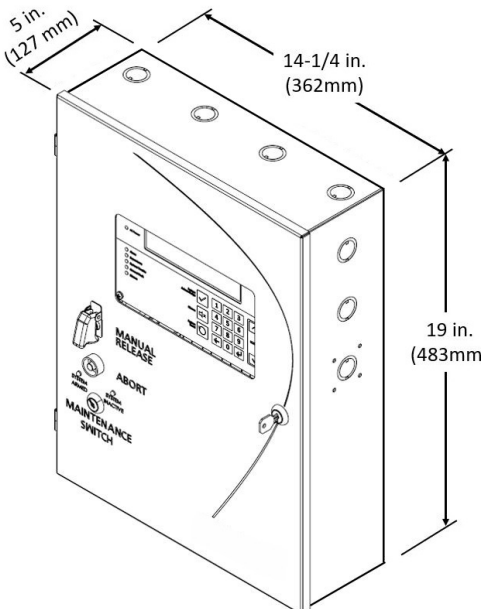

## EVENT-OUTPUT-CONTROL (EOC)

A built-in code is available to program the AEGIS-PHX as desired for control-by-event scenarios. A series of conditional statements can be written to logically assign initiating points to control unit-based outputs, in addition to other programming features.

## USER INTERFACE

Alarm, trouble, and supervisory events are annunciated on a 160-character, backlit LCD display with integral status LEDs. Event acknowledgment, alarm silence, and system reset are accomplished with dedicated control keys. Basic user and maintenance operations such as viewing event history or isolation of initiating points and system outputs are performed via the control keys and keypad. Two levels security passwords are incorporated to prevent unauthorized access.

## REAL TIME CLOCK

A dedicated real-time clock contained within the micro-processor adds a timestamp to event logging and time-keeping. A 12/24-hour option is available for viewing purposes.

## SYSTEM MENUS

In addition to being able to configure the control unit remotely, the AEGIS-PHX control unit utilizes comprehensive menu-based software from the keypad. List, Set, Isolation and Testing are the primary menus with various submenus available. Control, programming and testing can be accessed using the keypad and control keys.

## TROUBLESHOOTING

Descriptive error messages and event logs with time/date stamp information (compatible with the IntelliSite™ IoT Platform) make troubleshooting easier.

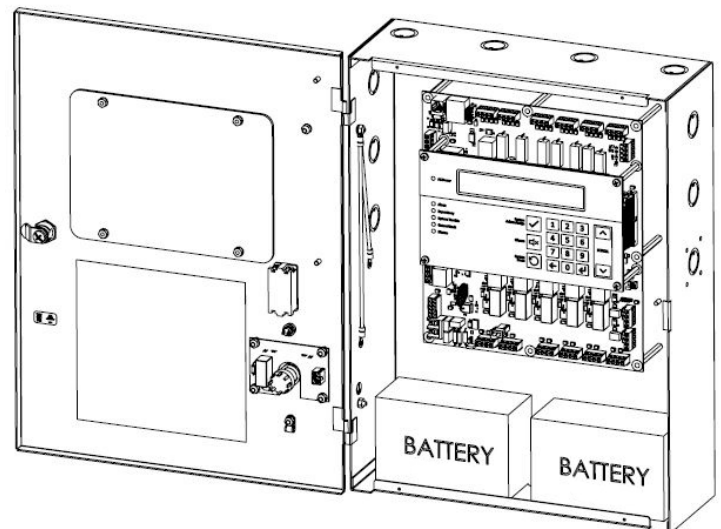

## SPECIFICATIONS

ITEM	DESCRIPTION
<b>POWER:</b>	
Primary AC Power	120 VAC, 50/60 Hz or 220/240 VAC
Current Consumption	3.2 Amps (120 VAC) or 1.6 Amps (220/240 VAC)
Power Supply Output	5.4 A @ 24 VDC, Filtered and Regulated, Inherently Power-Limited 27.7 ± 0.2 VDC
Battery Capacity	Up to 70 AH @ 24 VDC
Battery Cutout Voltage	19.5 VDC
Battery Transfer	85% of 120 VAC or 85% of 240 VAC
Real-Time Clock Battery	3V Lithium coin cell (Typical life is 10 years in standby mode) Error message/trouble occurs for low voltage.
<b>INPUT CIRCUITS:</b>	
<b>Initiating Device Circuits (IDCs)</b>	Seven (7)
<p>Compatible Devices</p> <p>Refer to AEGIS-PHX Fire Alarm Control Unit Detector Compatibility Table, Document P/N K-84-901 (found on Distributor Extranet site).</p> <p>Note: Circuits subject to 100 Ohm maximum wiring resistance.</p>	<ul style="list-style-type: none"> <li>- Photoelectric Smoke Detectors: KC2-OS-CD (13), SOE-24V (20)</li> <li>- Combination Photoelectric-Heat Detectors: KC2-OSH-CD (13), SOE-24H (20)</li> <li>- 2 wire Duct Detector: SD-2W (5)</li> <li>- Heat Detector: KC2-H-CD (13)</li> <li>- Linear Heat Sensor (LHS): 1728 ft. max. for both Class A and B wiring, no lead in wire</li> <li>- Detect-a-Fire Heat Detectors: 27x21-xx, 28021-5 *</li> <li>- Fenwal Controls 08-84 Heat Detectors: 08-841xx-xxx (N.O.) *</li> <li>- Normally Open switch inputs, including those from Manual Release Stations, Abort Stations, Flow Switches, Pressure Switches, etc.*</li> </ul> <p>* No limit on the number of contact devices other than the total wire resistance (100 ohms)</p>
Circuit Type	<ul style="list-style-type: none"> <li>- Class A or Class B supervised</li> <li>- Detects Opens and Ground Faults</li> <li>- Power Limited</li> </ul>
Circuit Voltage	Nominal 24 VDC, 28 VDC maximum
Maximum Line Resistance	100 ohms per circuit
Maximum Alarm Current	71.3 mA
End-of-Line Resistor	5.1 K, ± 5%, 1/2 W
<b>OUTPUT CIRCUITS:</b>	
<b>Release-Notification Appliance Circuits (R-NACs)</b>	Five (5)
Each Configurable as:	<ul style="list-style-type: none"> <li>- Class A or Class B NAC, rated 24 VDC, 1.5 A (maximum per circuit) Regulated, Suitable for Synchronized Notification Appliances</li> <li>- Release Circuit with One Control Head or Solenoid Valve, 24 VDC</li> <li>- Legacy Kidde actuators or Fenwal initiators</li> </ul>

<b>When Configured as NAC:</b>	Any 5 R-NAC Circuits
Compatible Devices	- 1.5 A (maximum current per circuit) using polarized 24 VDC regulated UL Listed Notification Appliances subject to the maximum allowable voltage drop per circuit. - Compatible with Eaton (Wheelock and Eluxa) synchronization protocols
Circuit Type	- Class A or Class B supervised - Detects Opens, Shorts and Ground Faults - Power Limited
Circuit Voltage in Alarm Condition	Nominal 24 VDC regulated, 28 VDC maximum
Total Allowed Circuit Voltage Drop	2 V
End-of-Line Resistor	5.1 K, $\pm$ 5%, 1/2 W
<b>When Configured as Releasing:</b>	Any 5 R-NAC Circuits
Compatible Devices (A complete list can be found in Appendix B of the <i>AEgis-PHX Design, Operation, Installation &amp; Maintenance Manual</i> , P/N 06-237919-001.)	- 1 Kidde Fire Systems control head per circuit - 1 FM Pre-Action/Deluge/Sprinkler Solenoid per circuit - Fenwal Protection Systems initiators - Kidde Fire Systems actuator
Circuit Type	- Class A (Control Heads and Solenoids only) - Class B - Class E - Detects Opens and Ground Faults - Power limiting and short circuit detection options enabled with In-Line Releasing Device: P/N 76-80000-004 (Class A circuit) or P/N 06-220023-001 (Class B circuit)
End-of-Line Resistor	Required for Class A wiring only, 5.1K, 5%, 1/2 W
Key Maintenance Bypass Switch	Required on all non-water based Agent Release Circuits
<b>Dry Contact Output Relays</b>	Four (4) Three (3) Programmable: Normally de-energized with power on One (1) Trouble: Normally energized with power on and Normal state
Relay Type	Form-C rated 1 Amp @ 30 VDC (resistive)
<b>External Relay Outputs</b>	Two (2) Negative Pull-Down Open Collector Outputs
Relay Type	24 VDC Coil
Maximum Sink Current	50mA per circuit
<b>Auxiliary Power Outputs</b>	Two (2) Special Application 19.8 - 27.4 VDC @ 2A maximum Programmable to be resettable or non-resettable (A System Reset will interrupt the Auxiliary Power Output for five (5) seconds, if configured as "resettable".)
Circuit Type	Class B, Power Limited
Output Current - Alarm	2 Amp maximum Alarm on each output @ 19.8 - 27.4 VDC
Output Current - Standby	For systems with 24-hour battery backup requirement: AUX1 and AUX2 combined total output cannot exceed 2 A maximum @ 19.8 - 27.4 VDC For systems with 90-hour battery backup requirement: AUX1 and AUX2 combined total output cannot exceed 400 mA max @ 19.8 - 27.4 VDC

COMMUNICATION:	
RS-232 Serial Port	Unidirectional, 9600 Baud Rate, 8 Data Bits, 1 Start Bit, 1 Stop Bit No Parity (for IntelliSite Use)
TCP/IP (Ethernet)	For Direct PC Connection Only
Output to Central Station	Compatible with non-coded DAC when used with a UL Listed DACT

OPERATING ENVIRONMENT:	
Temperature	32°F to 120°F (0°C to 49°C)
Relative Humidity	93% RH @ 90°F non-condensing

ENCLOSURE:	
Degree of Protection	NEMA 1 For indoor, dry use only
Material of Construction	16 Gauge (0.059 in. or 1.5 mm) sheet steel
Color	Red
Enclosure Only Dimensions	14-1/4 in. Width x 5 in. Depth x 19 in. Height (362 mm x 127 mm x 483 mm)
Enclosure With Door Dimensions	14-13/32 in. Width x 5-1/16 in. Depth x 19-5/32 in. Height (366 mm x 129 mm x 487 mm)
Approximate Weights (Without Batteries and Door Switches)	- Standard Unit: 18 lbs. (8 kg) - Standard Unit, Packed for Shipment: 21 lbs. (9.5 kg)

## ORDERING INFORMATION

Part Number	Description
84-900001-001	AEGIS™-PHX Control Unit Assembly
84-900001-002	AEGIS™-PHX Control Unit Assembly, with Door-Mounted Manual Release, Abort and Key Maintenance Bypass Switch Installation Kits
76-600000-007	Trim Ring for AEGIS-PHX Enclosure
84-900150-001	Spare AEGIS-PHX Printed Circuit Board with User Interface
06-220149-001	Spare Hardware Installation Kit

Part Number	Description
84-900176-001	AEGIS-PHX Door-Mounted Manual Release and Abort Switch Installation Kits
84-900732-001	AEGIS-PHX Retrofit Kit with PCB and Solid Door (No Door-Mounted Switches)
84-900732-002	AEGIS-PHX Retrofit Kit with PCB and Door with Holes for Abort and Manual Release Switches  (Switches ordered separately or removed from legacy panel and re-installed.)

### EXPORT INFORMATION (USA)

Jurisdiction: EAR

Classification: EAR99

This document contains technical data subject to the EAR.

This literature is provided for informational purposes only. Kidde-Fenwal, LLC believes this data to be accurate, but it is published and presented without any guarantee or warranty whatsoever. Kidde-Fenwal, LLC assumes no responsibility for the product's suitability for a particular application. The product must be properly applied to work correctly. If you need more information on this product, or if you have a particular problem or question, contact KIDDE-FENWAL, LLC, Ashland, MA 01721.

Kidde-Fenwal, LLC  
400 Main Street  
Ashland, MA 01721, USA

KFI U.K. Limited  
Station Road,  
Bentham, Lancaster, LA2 7NA

Kidde Technologies  
Survey No. 28/2, 44/2 and 45  
Rasyani, Dandapta Road  
Raigad Maharashtra-410207, India



[kiddefenwal.com](http://kiddefenwal.com) | 508.881.2000

Kidde Fire Systems, Kidde Fire Protection and Fenwal Controls branded products are created exclusively by Kidde-Fenwal, LLC. All other trademarks are the property of their respective owners.

2026 © Kidde-Fenwal, LLC | All Rights Reserved

P/N: K-84-900 Rev. AF