

Low Pressure CO₂ Fire Suppression Systems

Kidde Fire Systems' CARDOX® Low Pressure Carbon Dioxide system (Cardox LPCO₂) is the ideal fire suppression solution for heavy and light industrial applications where unoccupied spaces or assets need protection, where CO₂ is an acceptable agent, where fires occur frequently requiring regular agent replenishment, where other agents would be cost prohibitive, and where in addition to the primary total flooding design, a local application system may be required. The CO₂ agent is stored in a refrigerated state at 300 psi in an insulated steel tank, typically located outdoors.

Features

Environmentally safe

- CO₂ is naturally occurring gas
- Global Warming Potential (GWP) of One (1)
- Ozone Depletion Potential (ODP) of Zero (0)

Wide range of end-use verticals - broad opportunity

Since CO₂ is a gas, it can penetrate and spread to all parts of the protected area. As a gas or as a finely divided solid called 'snow' or 'dry ice', CO₂ will not conduct electricity and therefore, can be used on energized electrical equipment. CO₂ also leaves no residue, thus eliminating cleanup of the agent itself. Additionally, CO₂ is low-cost, therefore can be used on deep-seated fires and oils, fats and greases where larger agent quantities are required.

A sampling of industries using Cardox LPCO₂ include:

- Manufacturing
 - Automotive Plants
 - Cement Plants
 - Industrial Food Fryers
- Power Generation
 - Turbine Enclosures
 - Coal Handling Systems
 - Fume Handling Systems
 - High Voltage Switchgear
- Metals
 - Rolling Mills
 - Metal Processing
- Other Industries
 - Printing Presses
 - Flammable Materials Storage

A choice of hardware profiles to suit various application types and requirements:

- Tank capacity range (tons) enables use in small to large facilities:
 - Small: 2.75, 3.75, 4, 6, 8, 10 tons
 - Medium: 12, 14, 18, 22, 26 tons
 - Large: 30, 34, 38, 42, 46, 50, 60 tons
- Tanks are also constructed in vertical configuration to suit specific site needs:
 - Small: 6, tons
 - Medium: 14, 26 tons
 - Large: 30 tons



- Range of refrigeration system voltages allow for global use:
 - 120V: 60Hz 1-Phase
 - 220V: 50Hz 1-Phase, 60Hz 1-Phase, 60Hz 3-Phase
 - 460V: 60Hz 3-Phase
- Selector valves allow cost-effective protection for facilities with several assets requiring protection.

Additional options enhance user-friendliness, safety and/or end-use regional accessibility

- Liquid Level Gauge with Dual (NO/NC) Contacts
- Liquid Level Gauge with 4-20mA Output Signal
- Redundant Safety Relief Valve Set
- Heavy Wall Pressure Vessel
- Cold Weather Instrumentation Package

Wide operating temperature

- Range of -10 to 130 °F (-23 to 54 °C) allows extreme installation environments.

Specify with confidence!

- Approved by Factory Mutual
- 3.75 ton to 12 ton units carry Canadian Registration Numbers (CRN) for pressure vessels
- Canadian Standards Association (CSA) and Pressurized Equipment Directive (PED) approvals upon request

Suppression System Configuration

Cardox LPCO₂ systems may be configured for total flooding, local application, or both.

Total Flooding systems are designed to essentially 'flood the space' by discharging a pre-calculated amount of CO₂ through a network of fixed piping and nozzles into the enclosed space around the hazard. Since suppression is based on achieving a minimum concentration of CO₂ in the space, the space around the asset must be totally enclosed or all openings must be automatically closed prior to or at the start of system discharge. If all openings cannot be closed, additional CO₂ must be provided to compensate for agent loss during the discharge and appropriate concentration retention periods. The CO₂ concentration must be maintained for a sufficient period to allow the fuel and any other surfaces or equipment in contact with the fuel to cool below the ignition temperature of the combustibles.

Local Application systems differ from total flooding in that the nozzles are arranged to discharge directly onto the fire. Local application is practical where the protected equipment can be isolated from other combustibles so the fire will not spread beyond the area protected, and where the entire hazard can be protected by the discharge. The principal uses of local application systems is the protection of open tanks containing flammable liquids. This technique is also very effective for three-dimensional assets such as paint spray booths and printing presses. Suppression by local application is transitory and will be effective only if the suppression occurs quickly and all potential re-ignition sources are eliminated.

Technical Specifications

Material:	SA-612 normalized CS
Max. Working Pressure:	350 psig (24.1 bar)
Minimum Design Metal Temperature:	-40 °F (-40 °C)
Operational Temperature	
Minimum:	-10 °F (-23.3 °C)
Maximum:	130 °F (54.4 °C)
Piping:	Sch 80 seamless
Fittings:	2000 lb. forged fittings
Insulation:	
Horizontal units:	4 in. polyurethane
Vertical units:	6 in. polyurethane
Refrigerant:	R-404A
Instrumentation:	
Liquid Level:	6 in. (152.4 mm) dial gauge
Pressure:	6 in. (152.4 mm) dial gauge
Audible Alarm:	High/Low Pressure
Electrical Cabinet:	NEMA 3R

Common System Components

- "Low Pressure Carbon Dioxide Storage Tanks" on page 2
- "Lockout Valves" on page 3
- "Safety Relief Valves" on page 3
- "Selector Valves" on page 4
- "Check Valves" on page 4
- "Discharge Nozzles" on page 4
- "Pressure Operated Sirens" on page 6
- "Discharge Delay Devices" on page 6
- "Odorizer Assembly" on page 7
- "Warning Signs" on page 7

Low Pressure Carbon Dioxide Storage Tanks

Cardox LPCO₂ tanks incorporate the design, construction, and testing requirements specified in the American Society of Mechanical Engineers (ASME) Boiler & Pressure Vessel Code, Section VIII, Division 1.

A 4 in. (100 mm) thick polyurethane layer sheathed inside an aluminum outer jacket insulates the steel pressure vessel while a factory installed low-temp air-cooled refrigeration package using R-404A refrigerant chills the CO₂ to approximately 0 °F at 300 psi (-17 °C at 20.6 bar). In combination, the insulation and refrigeration package provide efficient continuous duty operation, affording reduced facility overhead.

Each storage unit ships from the factory with one safety relief valve and two 6-inch (150 mm) diameter gauges, one for pressure and one for liquid level indication. Audible alarms are provided for high and low pressure.



Figure 1: LPCO₂ Storage Tanks

Note: For more information including dimensions, see datasheet K-64-001.

Lockout Valves

Lockout valves serve to isolate either the storage unit from the downstream discharge piping or individual hazard areas from the upstream suppression system. A lockout valve is installed in the distribution pipe and manually operated. The valve is normally open and must be locked in the closed position to prevent discharge of CO₂ into the protected space when either (a) persons not familiar with the system and its operation are present or (b) if persons are present in locations where system discharge will endanger them if they are unable to evacuate to a safe location within the time delay period.

A lockout valve shall be provided on all systems, except where dimensional constraints prevent personnel from entering the protected space and where discharged CO₂ cannot migrate to adjacent areas, creating a hazard to personnel. Lockout valves shall be supervised to provide notification of a lockout.

Two separate styles of lockout valves are available, wafer and ball. Each style incorporates a bolt hole to accommodate a padlock furnished by the installer. When affixed, the padlock secures the valve in the position set. For either style, only a manual operation will change the valve position. Both styles may be selected with a factory fitted combination limit switch and visual position indicator package. When selected with a limit switch, either a NEMA 4 & 4X housing or a NEMA 4, 4X, 7 & 9 housing may be selected.

Wafer Valve

Wafer valves are typically used on larger diameter pipes of sizes 3, 4, 6, and 8 inches. The wafer valves may be fitted to either the flanged discharge outlet on the storage tank or to the discharge piping.

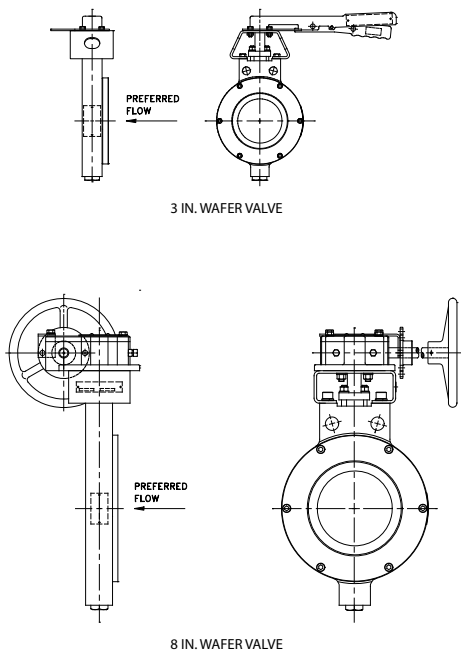

Figure 2: Wafer Valves

Note: For more information including dimensions, see datasheet K-64-200, K-64-210, and K-64-220.

Ball Valve

Ball valves are typically used on small diameter pipes sizes of 1/4 to 2 inches. The valves are in all stainless steel construction and have NPT inlet and outlet connections. The ball valves also incorporate a self-relieving seat design, which allows any liquid CO₂ retained between the seals to safely vent away after setting the valve to the closed position.

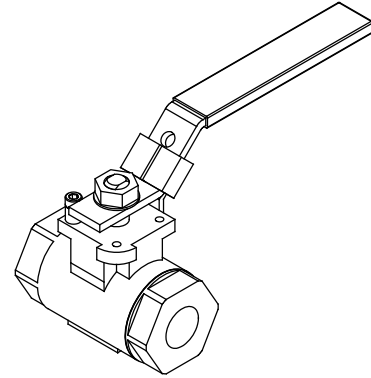

Figure 3: Ball Valve, Stainless Steel (without Limit Switch)

Note: For more information including dimensions, see datasheet K-64-100, K-64-110, and K-64-120.

Safety Relief Valves

Safety relief valves are fitted to sections of the system piping where the system pressure may exceed the maximum pressure rating of the attached components due to changes in the ambient temperature. The nominal relief pressure ranges from 100 to 450 psi depending on the valve's location and configuration.

A 450-psi safety relief valve is installed upstream of each selector valve. When the selector valve is used as a master valve, the safety relief valve is installed between the master valve and the tank shut off valve. A Safety Relief Valve set to 375 psi is placed downstream of the lockout valve. Lower pressure Safety Relief Valves are used for pilot line applications.

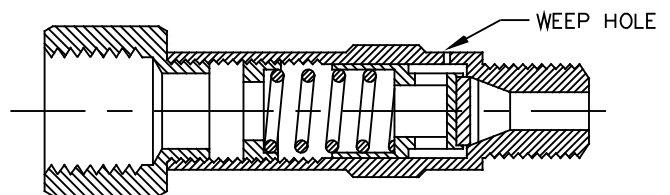

Figure 4: Safety Relief Valve

Selector Valves

Selector valves allow cost-effective protection for facilities with multiple hazards requiring protection or as a safety device. A system protecting multiple hazards requires one selector valve for each hazard, with only the selector valve to the hazard operating at the time of discharge. A selector valve, when used as a safety device, is employed to ensure that CO₂ is not discharged into a normally occupied area without an evacuation signal. The valve is normally closed to prevent the flow of CO₂ into the distribution piping. Automatic or manual action is required to open the valve and allow CO₂ to be discharged.

Two styles of selector valves are available, ball valves for smaller size piping and wafer valves for larger diameter pipes. Both valves require pressure to function. These valves direct the flow of CO₂ through the suppression system. When a system protects a single hazard area, the selector valve restricts the flow of CO₂ into the hazard until commanded by the interfacing fire suppression panel during an alarm event. When a single system protects multiple hazard areas, the selector valves allow discharge only into the hazard in alarm.

Note: For more information, see datasheet K-81-5130, K-81-5140, and K-81-5150.

Check Valves

Check valves serve to isolate a specific section of the suppression system from the entire system. All of the check valves feature brass bodies.



Figure 5: 1/4 in. Check Valve

Discharge Nozzles

Discharge nozzles control the distribution of CO₂ into the protected area for total flooding or onto the protected equipment for local application. These discharge nozzles are designed to provide the proper combination of flow rate and discharge pattern to protect vital equipment. See Table 1 for more information on nozzle styles and applications.

Discharge nozzles are marked to identify the nozzle and show the nozzle's equivalent single orifice diameter. The equivalent diameter refers to the orifice diameter of a "standard" single orifice type nozzle having the same flow rate as the discharge nozzle. The orifice code numbers indicate the equivalent single-orifice diameter in 1/32-inch increments. A plus (+) symbol is used to indicate a 1/64-inch increment.

Strainers are provided with nozzles having smaller orifice sizes to prevent foreign objects in the pipe from clogging the nozzle orifice.

A Flange Mounting kit is available for Type S Multijet nozzles, Type V Vent nozzles, and Spot Nozzles.

Table 1. Nozzle Styles

Nozzle Type	Application	Nominal Spray Pattern
Multijet Type S	Total Flood -or- Local Application Rate by Volume	Cone
Multijet Type S, Flange		
Multijet Type S, Coated		
Multijet Type M		
Vent Type V	Total Flood	Jet
Radial	Total Flood	Style A = Jet Style B = 180° Style C = Jet, back-to-back Style D = 360°
Orifice, without Cap	Total Flood	Jet
Orifice, with Cap		
Orifice, Threaded Outlet		
Spot, Flange, 4 or 5 1/2 in. OD	Total Flood -or- Local Application Rate by Area -or- Local Application Rate by Volume	Cone

Note: See flow calculation report for nozzle part numbers and drill codes.

Multijet Nozzle, Type S

The type S multijet nozzles have a female 1/2 in. NPT inlet connection for attaching to the CO₂ distribution piping. The basic type S nozzle has a red painted cold-rolled steel body. A flanged type S nozzle and flanged mounting kit are also available for mounting the nozzle on the exterior of a duct or enclosure. The flanged mounting kit includes a frangible disc which ruptures upon discharge to allow flow from the nozzle. The flanged nozzle and mounting kit may be used to prevent particulate and liquid matter from clogging the orifices. The flanged nozzle body is painted red.

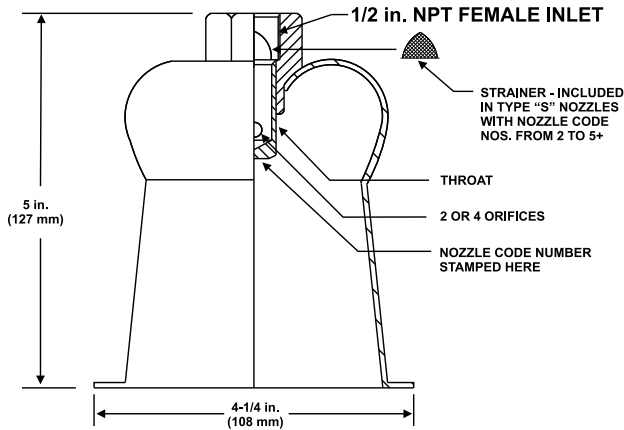

Figure 6: Multijet Nozzle, Type S Flanged

Note: For more information, see datasheet K-81-1130 and K-81-1170.

Multijet Nozzle, Type M

The type M multijet nozzle is similar in design and operation to the type S multijet nozzle, and is used for applications requiring higher flow rates than those attainable with the type S nozzle. The nozzle body is longer than the type S body in order to accommodate the higher flow rates. The type M nozzle has a red painted, cold-rolled steel body and a 3/4 in. NPT inlet connection for attaching to the CO₂ distribution piping.

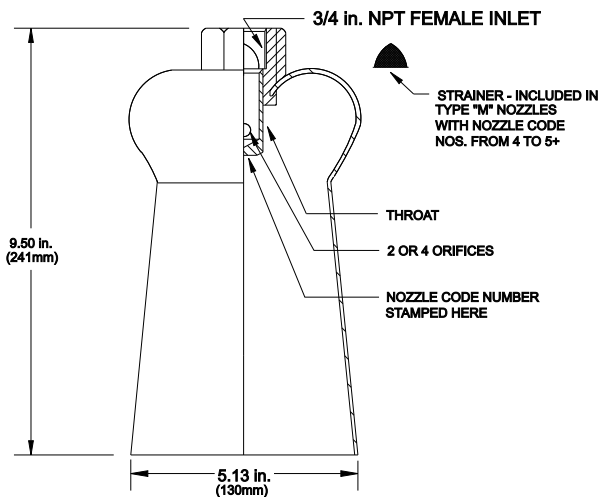

Figure 7: Multijet Nozzle, Type M

Note: For more information, see datasheet K-81-1150 and K-81-1170.

Vent Nozzle, Type V

The type V vent nozzle is a single-orifice nozzle used to discharge a jet of CO₂ into an enclosure such as a duct. The type V nozzles are only used for total flooding applications.

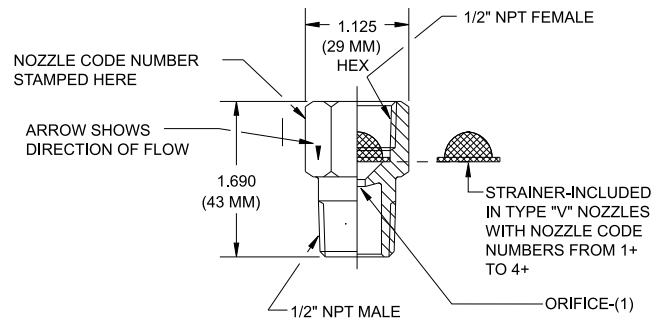

Figure 8: Vent Nozzle, Type V

Note: For more information, see datasheet K-81-1110, K-81-1120, and K-81-1170.

Radial Nozzles

Stainless steel radial type nozzles can be used in total flooding applications for delivering CO₂ into the protected space. The radial nozzles are available with connections ranging from 1/4 to 2 in. NPT sized. The radial nozzles are available in four styles in order to obtain the most desirable discharge pattern for proper distribution, namely:

- Style A = Single orifice port (straight line single jet discharge)
- Style B = Two orifice ports spaced at 90° apart (90-deg fan jet discharge)
- Style C = Two orifice ports spaced at 180° apart (fore & aft straight line single jet discharge)
- Style D = Four orifice ports spaced at 90° apart (360-deg fan jet discharge)

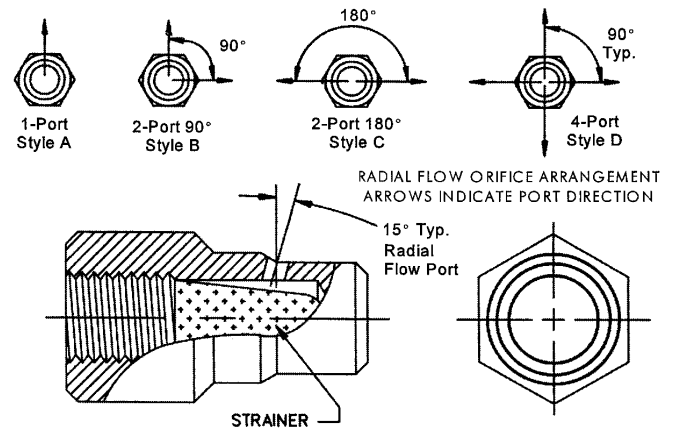

Odorizer Assembly

CO₂ is odorless and colorless. Therefore for the safety of personnel who may occupy the hazard area, odorizer assemblies are required with each CO₂ system regardless of size. Odorizers are used to inject wintergreen scent into the CO₂ discharge as a means to warn occupants of the presence of CO₂. Upon discharge, the CO₂ pressure ruptures a burst disc to release the scent intermixing it with the CO₂.



Figure 12: Odorizer

Note: For more information, see datasheet K-81-9162.

Warning Signs

Warning signs shall be posted inside and outside all areas protected by a CO₂ system, and in adjoining areas where the CO₂ could migrate. These warning signs instruct the occupants to evacuate the area immediately when the alarms operate, as well as to warn personnel not to enter the protected space after a CO₂ discharge until the area has been safely ventilated. Kidde Fire Systems offers different safety warning signs with wording specific to each application.

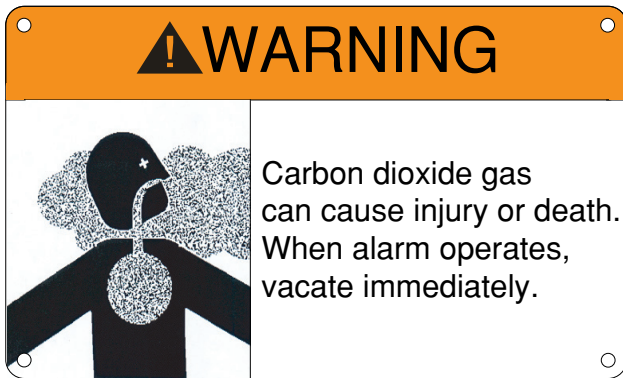

Figure 13: Sign in Every Protected Space

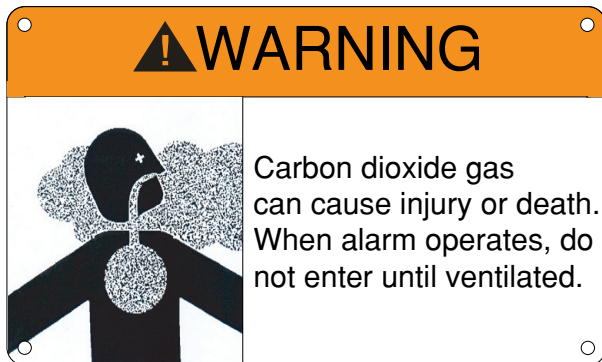

Figure 14: Sign at Every Entrance to Protected Space

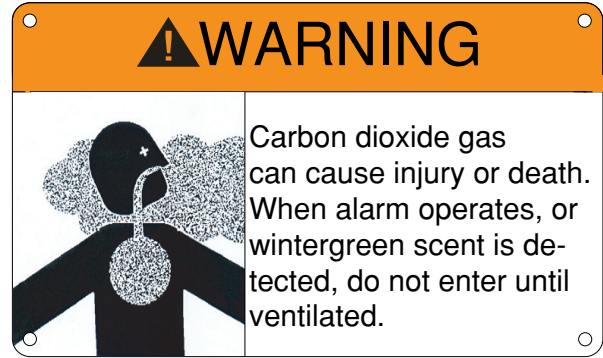

Figure 15: Sign at Every Entrance to Protected Space for Systems Provided with a Wintergreen Odorizer

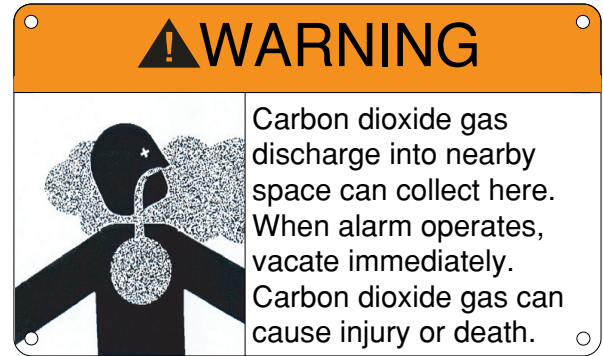

Figure 16: Sign in Every Nearby Space Where Carbon Dioxide Can Accumulate to Hazardous Levels

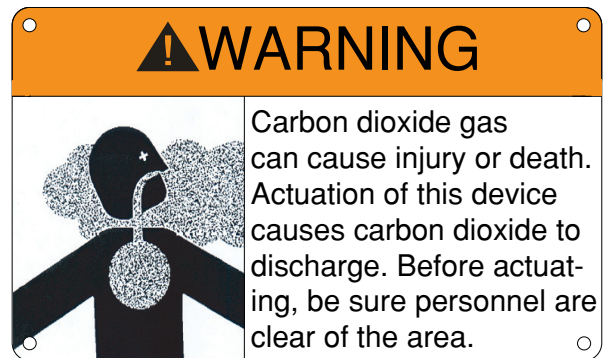

Figure 17: Sign at Each Manual Actuation Station

Note: For more information, see datasheet K-81-9171.

Post Discharge Cleanup

CO₂ can be lethal at certain concentrations. For the safety of the personnel after a discharge, ensure all air-exchanging equipment is turned back on and all areas to where the agent was discharged or where the discharged agent could migrate, should be thoroughly ventilated and purged with fresh air.

EXPORT INFORMATION (USA)

Jurisdiction: EAR
Classification: EAR99

This document contains technical data subject to the EAR.

This literature is provided for informational purposes only. Kidde-Fenwal, LLC believes this data to be accurate, but it is published and presented without any guarantee or warranty whatsoever. Kidde-Fenwal, LLC assumes no responsibility for the product's suitability for a particular application. The product must be properly applied to work correctly. If you need more information on this product, or if you have a particular problem or question, contact KIDDE-FENWAL, LLC, Ashland, MA 01721.

kiddefiresystems.com
508.881.2000

Kidde Fire Systems, Kidde Fire Protection and Fenwal Controls branded products are created exclusively by Kidde-Fenwal, LLC.

Cardox is a registered trademark of Kidde-Fenwal, LLC. All trademarks are the property of their respective owners. All products are the property of their respective owners.

 **KiddeFenwal**

400 Main Street, Ashland, MA 01721
P/N: K-64-1000 Rev. AC | kiddefenwal.com | 508-881-2000
2025© Kidde-Fenwal, LLC | All Rights Reserved